

22"

GALVANIZED HIGH VELOCITY FAN



As shown:
Yoke Mount Standard



PS-Pedestal Stroller



CW-Column Wall Mount

Mounting Options

Weights: 105 lbs/48 kg

91 lbs/41 kg

SIZE	CFM	HP	FAN DIMENSIONS			DISTANCE AIR THROW	SHIPPING WEIGHT
			W	D	I.D.		
22"	5570	1/2	29"	16"	22 1/2"	100' / 30m	69 lbs/31 kg

Propeller: 20.75 " Diameter, 3 Blade GalvAlum (19 Degree)

Fan Inlet/Outlet: Galvanized 16 Gauge Spun Steel

Finger Guards: Galvanized
OSHA STANDARD Steel Mesh

RPM: 1725

Decible: 76.5 dba

Enclosure: TEAO Standard/Washdown Available

Frame: 56

Ambient Temperature: 40C

Duty Cycle: Continuous

Power Cord (115V Only): 12' Length

Coverage: 3600 Sq.Ft. Max

Voltage	Motor Amps	Running Amps
115V/208-230V*	6.0/2.9-3.0	5.4/2.6-2.7
208-230/460V	2.3-2.4/1.2	2.0-2.1/1.1
277V	3.6	3.2

* Standard

22" High Velocity Fan Air Flow Pattern

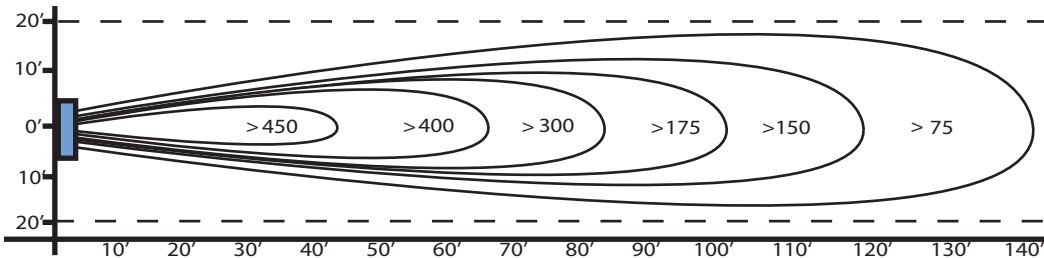

Above velocities shown in feet per minute.



10/12/09

Note: Due to continual product improvement, items are subject to change without notice.

Patterson Fan Company, Inc
Blythewood, SC 29016
www.pattersonfan.com
800.768.3985



YM Yoke Mount

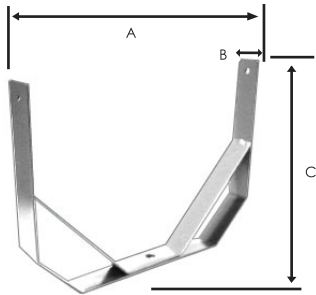

SIZES	MOUNT DIMENSIONS			SHIPPING WEIGHT
	A	B	C	
YM-14"	14"	2"	14"	8 lbs/4 kg
YM-18"	19.5"	2"	14.5"	12 lbs/5 kg
YM-22"	24"	2"	18"	15 lbs/7 kg
YM-26"	28"	4"	19.5"	16.5 lbs/7.4 kg
YM-30"	30.5"	4"	20.75"	18 lbs/8 kg

CW Column Wall Mount

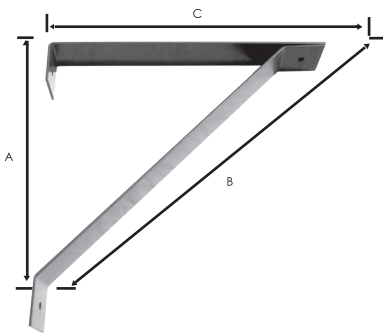

SIZES	MOUNT DIMENSIONS			SHIPPING WEIGHT
	A	B	C	
All Sizes: 14" - 30"	27"	38"	27"	22 lbs/10 kg

PS Pedestal StrollerMount

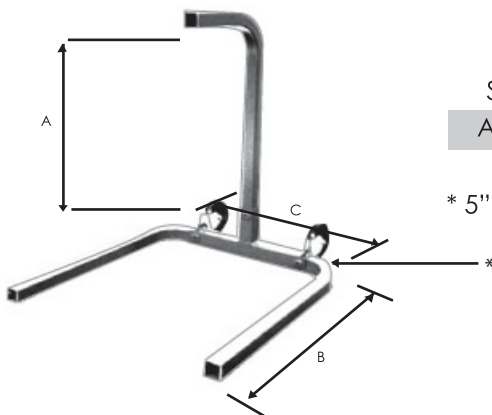

SIZES	MOUNT DIMENSIONS			SHIPPING WEIGHT
	A	B	C	
All Sizes: 14" - 30"	32"	35"	32"	38lbs/17kg

* 5" Castor Wheels

Contact your sales representative for available options.