



V-SERIES

INSTALLATION MANUAL

20' - 24'



PATTERSON

THE AUTHORITY IN AIR MOVEMENT

CONTENTS

BEFORE YOU START	3
IMPORTANT SAFETY INFORMATION	3
ITEMS INCLUDED IN YOUR FAN KIT	5
TOOLS NEEDED	5
FAN SPACING, PLACEMENT, & CLEARANCE	6
MAINTENANCE	7
MECHANICAL INSTALLATION	8
MOTOR ASSEMBLY	8
I-BEAM MOUNTING	9
SAFETY RETENTION SYSTEM	10
GUY WIRE ASSEMBLY	11
BLADE ASSEMBLY	12
ELECTRICAL INSTALLATION	13
BREAKER SIZING	13
CONNECT FAN CONTROL CABLE	13
RUN INPUT POWER CABLE	14
CONNECT VFD TO FIRE SUPPRESSION SYSTEM	15



Patterson Fan Company
1120 Northpoint Blvd.
Blythewood, SC 29016
(800) 768-3985
www.pattersonfan.com







IMPORTANT SAFETY INFORMATION



READ BEFORE OPERATING THE FAN AND SAVE THESE INSTRUCTIONS

 Read and understand these instructions before installing or operating a fan unit. Installation, adjustment, repair or maintenance must be performed by qualified personnel.



  Follow all safety practices and instructions during the installation, operation and servicing of the fan. Failure to apply these safety practices could result in death or serious injury. If you do not understand the instructions, please call your Patterson Sales Rep for guidance.

  All fan controls and incoming power should be installed only by qualified technicians familiar with the requirements of the National Electrical Code and local codes. Failure to follow these guidelines will void the manufacturer's warranty. All electrical controls are configured at the factory and are ready to use. No user adjustments are available. Follow the included installation instructions when installing this device to ensure proper operation. Do not make any changes to any part of the fan without first consulting Patterson Fan. Installation is to be in accordance with the National Electrical Code, ANSI/NFPA and applicable local codes.



  The user is responsible for compliance with all international and National Electrical Code requirements with respect to grounding of all equipment. Many of the parts of this unit operate at line voltage. **DO NOT TOUCH.** Install all covers before applying power or starting and stopping the unit. To reduce the risk of electric shock or injury, use this unit only in the manner intended by the manufacturer. If you have questions, call your Patterson Sales Rep at 1-800-768-3985.



  Before servicing or cleaning the unit, switch power off at the service panel and lock the service disconnecting means to prevent power from being switched on accidentally. When the service disconnecting means cannot be locked, securely fasten a prominent warning sign, such as a tag, to the service panel. At all times, leave the power off at the service panel. To reduce the risk of electric shock or injury, use this unit only in the manner intended by the manufacturer. If you have questions, call your Patterson Sales Rep at 1-800-768-3985.

DAMAGED EQUIPMENT

  Do not operate or install any fans or fan accessories that appear to be damaged. Failure to follow this instruction can result in death, serious injury, or equipment damage. Call your Patterson Sales Rep at 1-800-768-3985 immediately for guidance.

SERVICE

  If the fan does not operate properly using the procedures in this manual, remove all power to the unit and call your Patterson Sales Rep at 1-800-768-3985.

  Keep all body parts clear of moving parts at all times. All electrical troubleshooting and repair must be done by a qualified technician and meet all applicable codes.

KEY RETENTION SYSTEM COMPONENTS

 Our fans are engineered with key features to prevent pieces of the fan from falling in the unlikely event of a catastrophic failure. Used together, these systems provide comprehensive protection of people, equipment and property.

 Install the safety cable on EVERY fan. The safety cable, if installed per Patterson Fan specifications, will prevent the fan from falling in the unlikely event that the mounting system should fail.

 **The fan should never be run without a properly installed safety cable, which is supplied with every fan along with all required hardware. If the safety cable is not installed, the warranty will be voided.**

MARK THE FLOOR TO ALERT PERSONNEL

 When mounting a fan in an area where materials may be elevated into its path, we recommend alerting personnel of the overhead location of fans by marking the floor.



WEIGHT CONSIDERATIONS

 If there is any uncertainty in the strength of the building structure, a professional structural engineer should perform a thorough evaluation of the building prior to purchasing the fans. Patterson Fan provides guidelines for mounting fans; however, it is the sole responsibility of the building owner and installer to ensure the safety of the mounting system, that the building structure is sound, and that the installation complies with all federal, state, and local codes.

WARNING

 If unusual oscillating movement is observed, immediately stop using the fan and contact your Patterson Sales Rep at 1-800-768-3985.

CHECK FEDERAL, STATE, AND LOCAL CODES

  Check all relevant codes to make sure that all product certifications, product listings, and building regulations are met. Code compliance is the responsibility of the installer.

WINDY CONDITIONS

 Fans should not be operated in windy conditions or installed in locations where it is frequently windy.

ITEMS INCLUDED IN YOUR FAN KIT

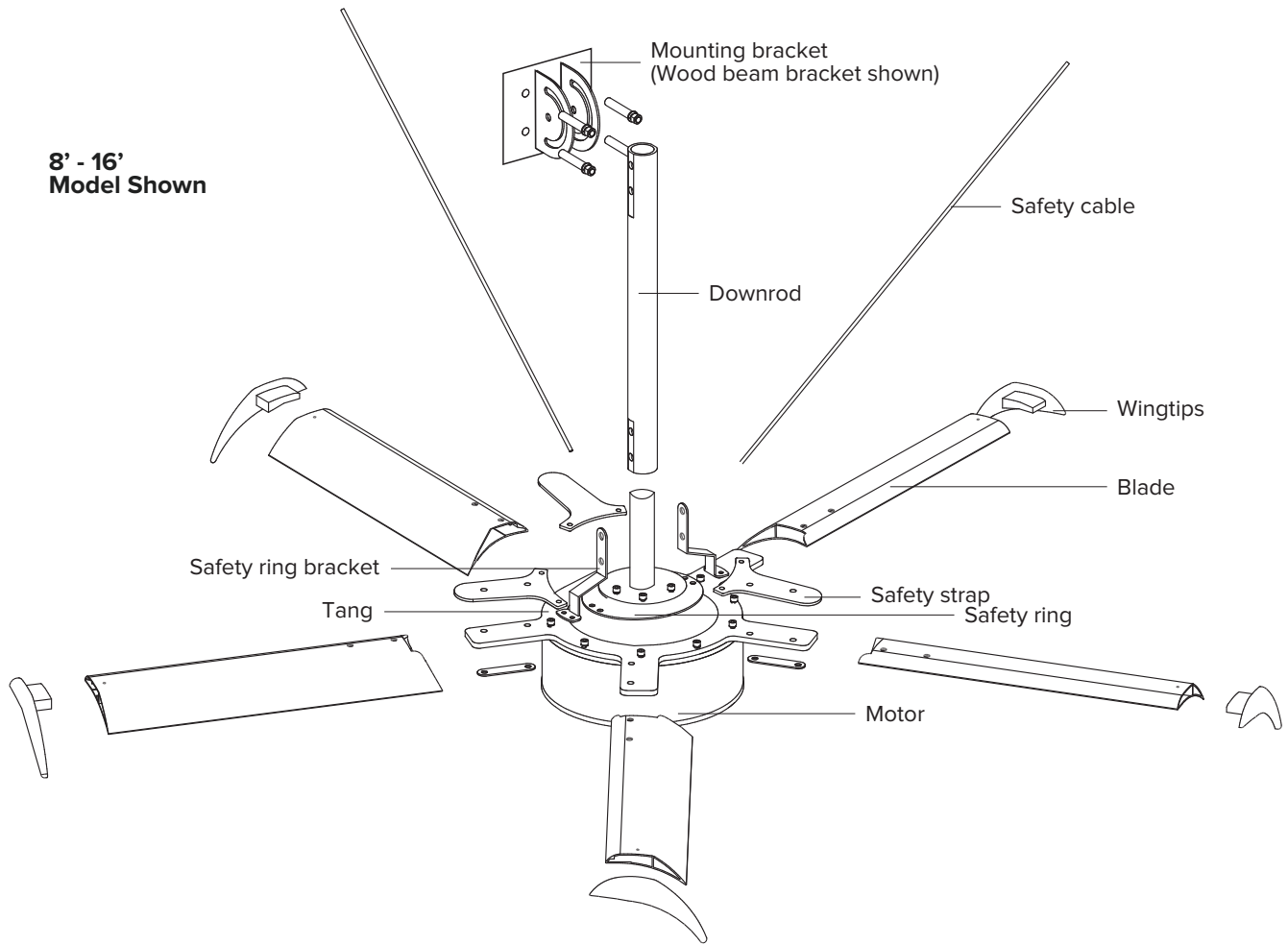

1. Concrete/wood beam bracket & hardware
2. I-beam mount & hardware
3. Downrod
4. Hand tools
5. Retention brackets & hardware
6. Guy wires & hardware
7. Safety cable & hardware
8. Wingtips
9. Electrical cable
10. Disconnect

TOOLS NEEDED

Hand tools (provided)
Level or plumb bob
Torque wrench

FAN SPACING, PLACEMENT, & CLEARANCE

SPRINKLER SYSTEMS AND FAN PLACEMENT

! In any installation where fire sprinklers are in place, the fan should not interfere with their correct operation. Fans should be located no less than 3 feet below a sprinkler, and placed in the center of nearest four sprinklers. Our industrial control panel can be connected to a fire relay system, which, in an emergency, will stop fans in case of fire.

! Prior to installing fans, review all codes applicable to sprinkler systems and fans to ensure code compliance and refer to NFPA 13 Standard from the National Fire Prevention Association. It is your sole responsibility to see that the installation is completed to code and that it is correct.

OTHER INFORMATION ON PLACEMENT AND SPACING

If possible, avoid mounting fans directly below lights or skylights to avoid any strobe effect caused by moving airfoils. Please see chart below for recommended minimum and maximum hanging heights.

! If the building has a mezzanine, fans should be mounted so a person cannot reach a fan in any way from the upper level/deck. Make certain that fans are positioned so that the airfoil tips are at least 3 feet away from any area where a person may be able to extend outward to reach them.

Fans should not be located directly beneath any air supply outlets or exhausting outlets. This includes air conditioning units and evaporative coolers. Such equipment can be used effectively in conjunction with HVLS fans but the discharge must be located outside of the swept area of the fan. Exhaust fan inlets or other return air points creating a negative pressure should not be within 1.5 times the diameter of the fan.

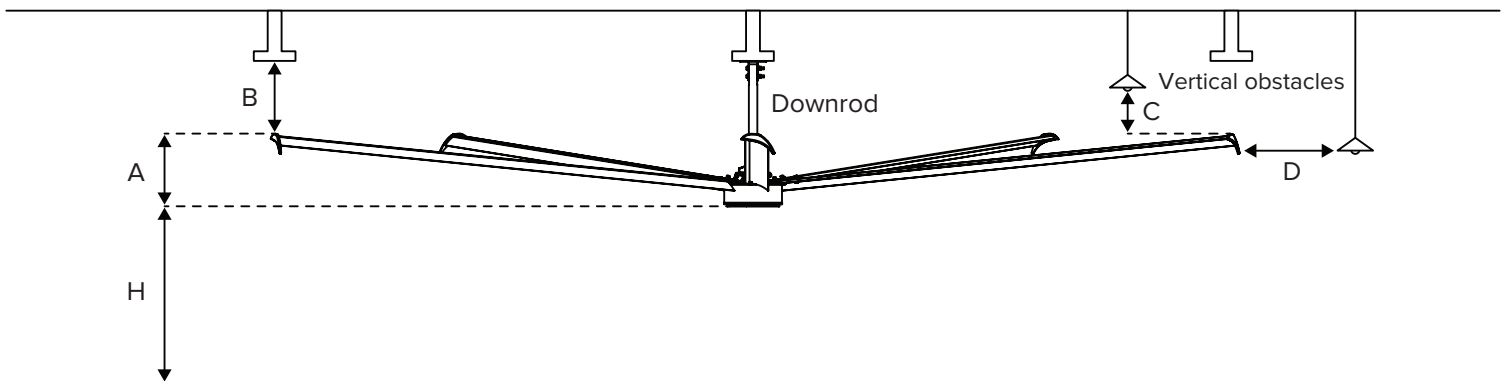

Size	H (min)	H (Rec max)	Assembled Height	A	B	C	D	Downrod
8'	10'	16.5'	31.5"	14"	12"	8"	8"	2' to 5'
12'	10'	16.5'	31.5"	15"	12"	8"	8"	2' to 5'
16'	12'	20'	31.5"	16"	12"	8"	8"	2' to 6'
20'	14'	23'	37"	20"	12"	8"	8"	2' to 10'
24'	14'	30'	37"	20"	12"	8"	8"	2' to 10'

MAINTENANCE



We strongly recommend that all equipment be included in your company's preventative maintenance program. Prior to performing any maintenance on the fan, it **MUST** be disconnected from the power source by means of the separate lockable disconnect (provided).

AIRFOIL CLEANING

Depending on the application of the fan, there can be quite a bit of dust or other particulates that cling to the fan's airfoils. We recommend fan owners keep airfoils clean by having a maintenance person or skilled trade professional - who has experience using a lift - wipe the fan airfoils with a rag or sponge using hot water or regular cleaning solutions. Please do not use chlorine or any chemicals containing chlorine.

RETENTION SYSTEM CHECK



Each fan must be installed with a retention system. The safety cable is attached to the motor and wraps around the building structure. The safety cable is an important part of the safety system and protects users if a catastrophic event occurs. It is critical for fan owners to ensure that it is intact and properly secured.

REPLACEMENT PARTS

Please call your Patterson Sales Rep at 1-800-768-3985 for parts.

MOTOR ASSEMBLY

1

Familiarize yourself with the assembly of the unit as shown in Image 1.

2

Place fan motor on flat surface with foam pad included in packaging and unpack retention kit.

3

Install retention brackets as shown in Image 2. Do not tighten hardware completely.

4

Install safety ring brackets onto safety ring and align as shown in Image 3. Tighten socket head screws to 16 ft-lbs.

5

Loosen safety strap hardware (to make mounting blades easier).

6

Remove the two bolts from the bottom of the downrod. Line up downrod, safety ring bracket, and retention bracket bolt holes and replace the two bolts. Make sure motor leads are aligned with junction box above. See Image 5.

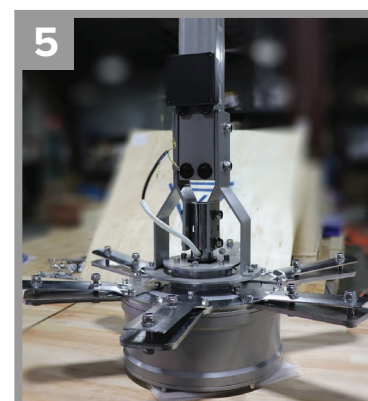
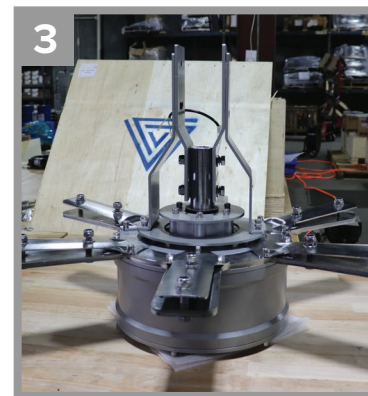
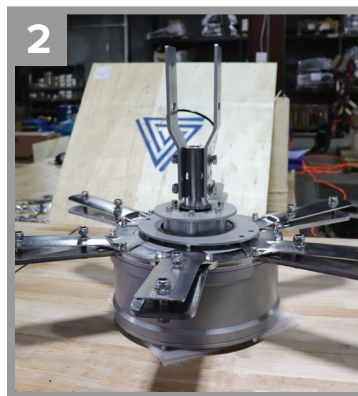
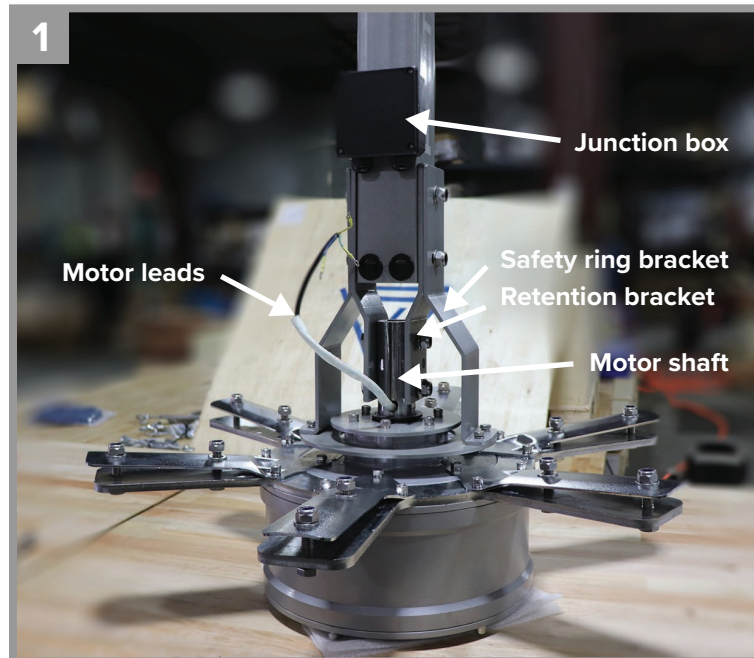

I-BEAM MOUNTING

Note: For other mounting options, please call your Patterson Rep at 1-800-768-3985.

1

Insert two bolts through one side of the I-beam mount and one beam clamp. Select the appropriate holes on the mount based on structure width; install bolts as close to I-beam as possible.

2

Place mount around I-beam and secure the remaining two bolts through the remaining beam clamp. Torque all four bolts to 55 ft-lbs.

3

Place the two top bolts of the downrod into the bolt opening of the mount. See Image 8.

4

With a level or plumb bob, make sure bottom of motor is completely horizontal.

5

Tighten all downrod and motor shaft bolts. Torque to 55 ft-lbs.



SAFETY RETENTION SYSTEM

 **Note:** This step is required. Failure to install the safety cable may void the manufacturer's warranty.

 **WARNING:** Do not put too much tension on the safety cable. A small amount of slack is needed for the safety cable to properly function. Avoid sharp edges.

1
Wrap safety cable around beam or building structure.



2
Run safety cable under downrod between retention brackets.

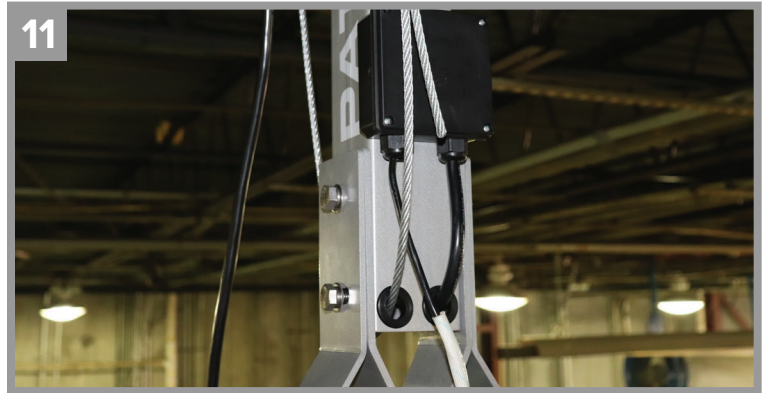

3
Overlap safety cable and secure with cable clamps.



GUY WIRE ASSEMBLY

⚠ WARNING: This step is required. Failure to install the guy wires properly may void the manufacturer's warranty and become a safety hazard.

1
Attach four guy wire assemblies to holes in retention bracket with quick link as shown in Image 15.

2
Loosen jam nuts and extend turnbuckle.

3
Run four guy wires to ceiling structure, keeping the angle less than 45° for maximum stability. Attach guy wires to ceiling structure using provided beam clamps and thimble. See Images 13 and 14.

4
Remove slack and secure with cable clamps.

5
Once all guy wires are in place, use the turnbuckles to take out any remaining slack. Periodically check the fan assembly with a level to ensure it remains in the vertical position. Continue adjusting by means of the turnbuckles until all cables are satisfactory. Guy wires should be taut, but not overstressed. Recheck all saddle clamps for tightness.

6
⚠ Tighten all jam nuts on turnbuckles as shown in Image 13. This step is required. Failure to install the guy wires properly may void the manufacturer's warranty AND become a safety hazard.

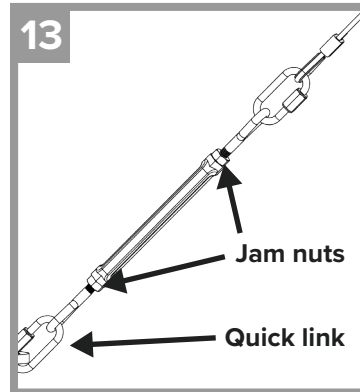

BLADE ASSEMBLY

1

Insert wingtips into the end of the blades and lock into place with two screws.

2

Remove blade bolts from tang. Loosen safety strap bolts and insert blade onto tang. Install the two blade bolts and double washer from below as shown Image 19. Torque to 32 ft-lbs.

3

Install washer and nut on top of blade bolt. Torque to 32 ft-lbs.
Do not torque blade bolts and nuts at the same time.

4

Torque safety strap bolts to 16 ft-lbs (two socket head screws and one hex cap screw). See Image 18.

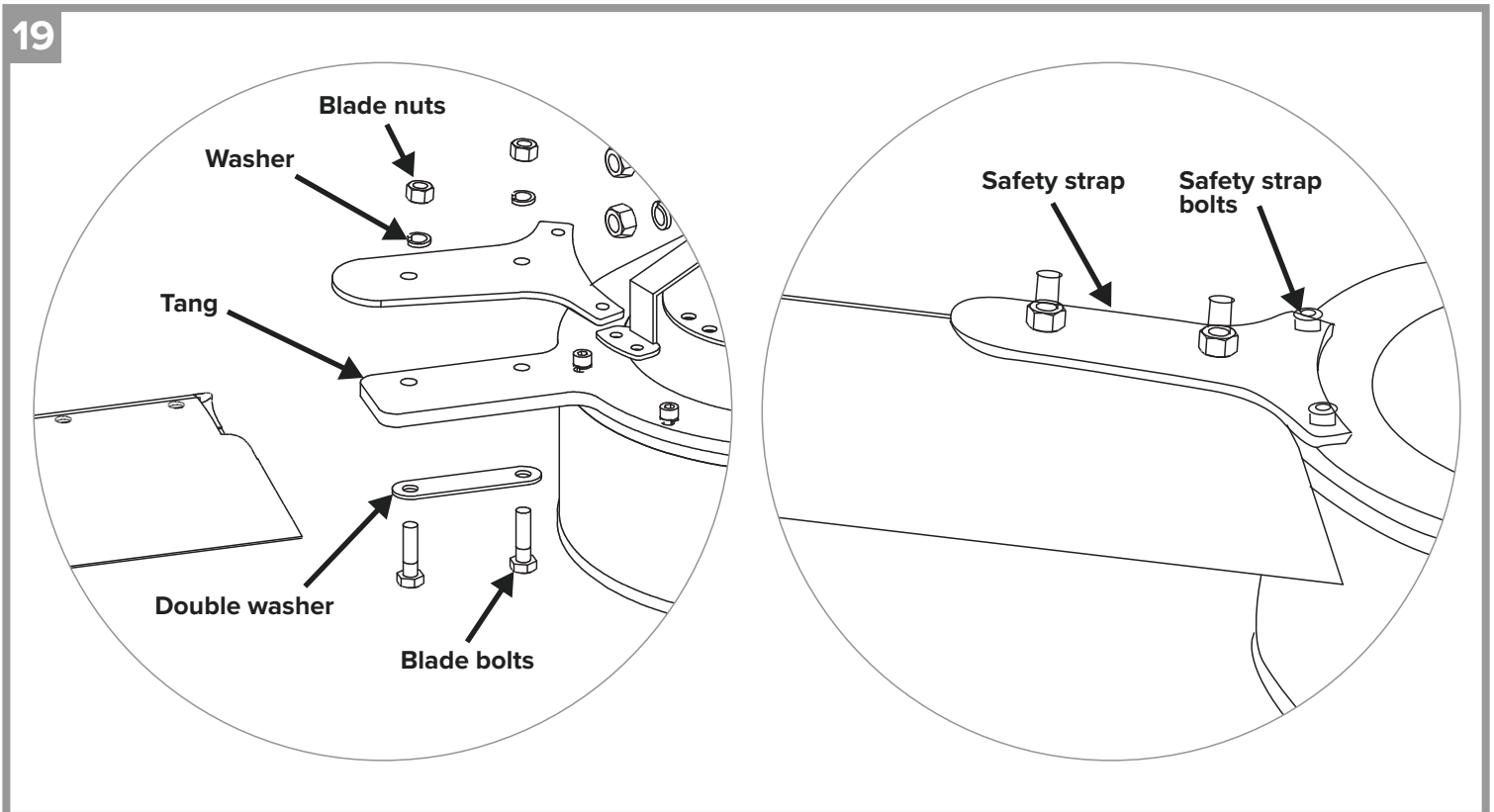

BREAKER SIZING

Refer to the table below for recommended circuit breaker sizing based on input voltage and fan motor horsepower.

VFD Model	Input V	Input Max Amp/ Recommended Fuse	Output V	Max Output A
EM30 Series	208-230V, 3Ø, 1.5 HP	11/15	0-Input, 3Ø	10
EM30 Series	460V, 3Ø, 1.5 HP	7.5/10	0-Input, 3Ø	6.5

CONNECT CONTROL CABLE TO FAN MOTOR

1
Remove the cover of the motor junction box on the downrod.

2
Feed motor leads through strain relief into junction box.

3
Pass end of VFD cable with ring terminals through strain relief into junction box.

4
Attach ring terminals from motor leads and VFD cable to terminals in junction box. Ensure letters match. See Image 20.

5
Route VFD cable to suitable VFD location (50' of cable has been provided). Conduit is recommended.

6
Mount VFD to wall by use of attached mounting tabs (hardware not included).

7
Run VFD cable through strain relief furthest to right. Connect cable to terminal blocks U, V, and W. See Image 21.

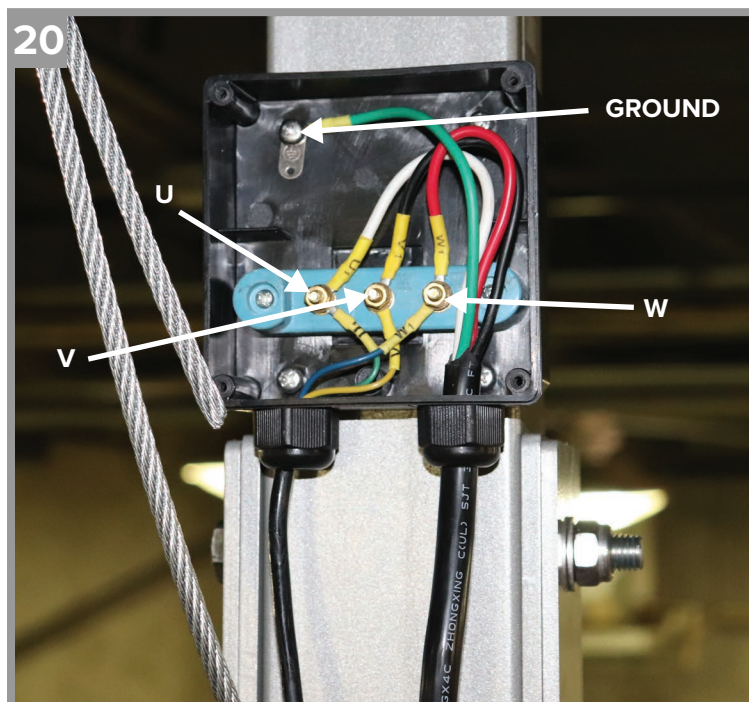

21

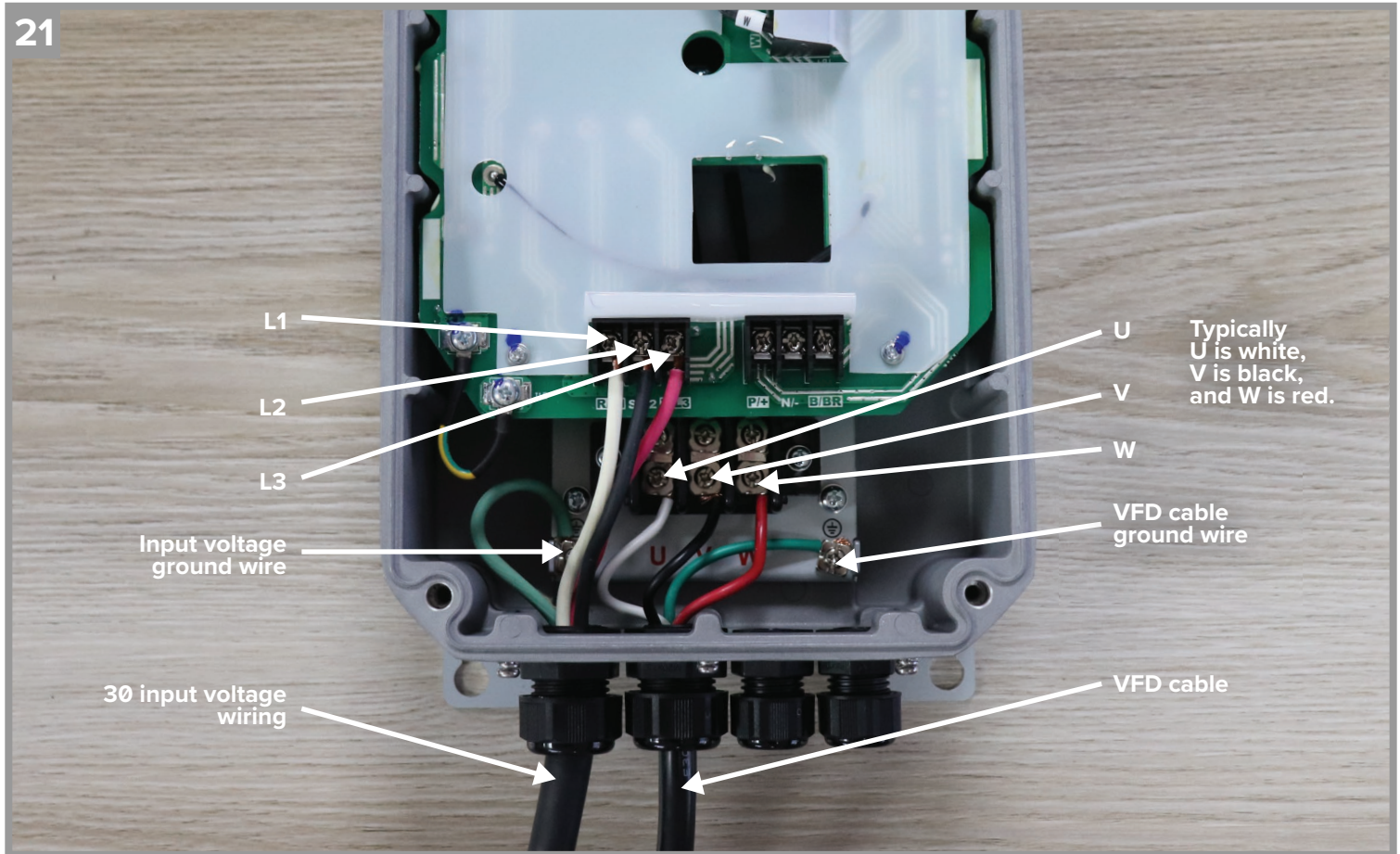

RUN INPUT POWER CABLE & INSTALL LOCKABLE DISCONNECT

⚠️ ⚡ WARNING: The Lockable Disconnect must be installed per local electrical codes. AT MINIMUM it must be installed outside the diameter of the fan blades.

⚠️ Note: If fan is spinning opposite of direction displayed on keypad, disconnect U and V wires, swap, and reconnect.

1

Be sure to size the input power cable properly for the application. Most installations will require 12-gauge wire. However, longer runs of power cable may require 10-gauge or higher.

2

Run input power into the top of the Lockable Disconnect, using the appropriately sized knockout.

3

Connect conductors to terminals L1, L2, and L3, respectively. Ground wire should be fastened to the protective earth (PE). Continue running input power to the drive by connecting three conductors to terminals T1, T2, and T3, respectively. A ground wire should be fastened to the protective earth (PE) provided. See Image 21.

4

Run the rest of the input cable near the wall mounted VFD. Using conduit for this run is recommended.

ELECTRICAL INSTALLATION



5

Connect the opposite end of the input power cable to the VFD. The three conductors should be connected to L1, L2, and L3, respectively. The ground wire should be connected in the manner shown in Image 21.



6

Reconnect Cat5 keypad cable to VFD and reattach cover.

CONNECT VFD TO A FIRE SUPPRESSION SYSTEM (IF REQUIRED)

  **WARNING: DO NOT connect external voltage to the fire suppression terminals. Fire suppression terminals should be connected to a relay via contacts. Placing voltage on the VFD terminal block will destroy the unit and void all manufacturers' warranties.**

  **CAUTION: DO NOT connect Patterson V-Series fans to the fans of another company for purposes of fire suppression. A separate line must be run for Patterson fans ONLY.**

  **CAUTION: If the drive will not be connected to any fire suppression system, the factory installed jumper across COM and DI2 MUST remain in place.**

1

Remove the factory installed jumper between terminals COM and DI2 on the upper terminal block. For more information, refer to Image 22.

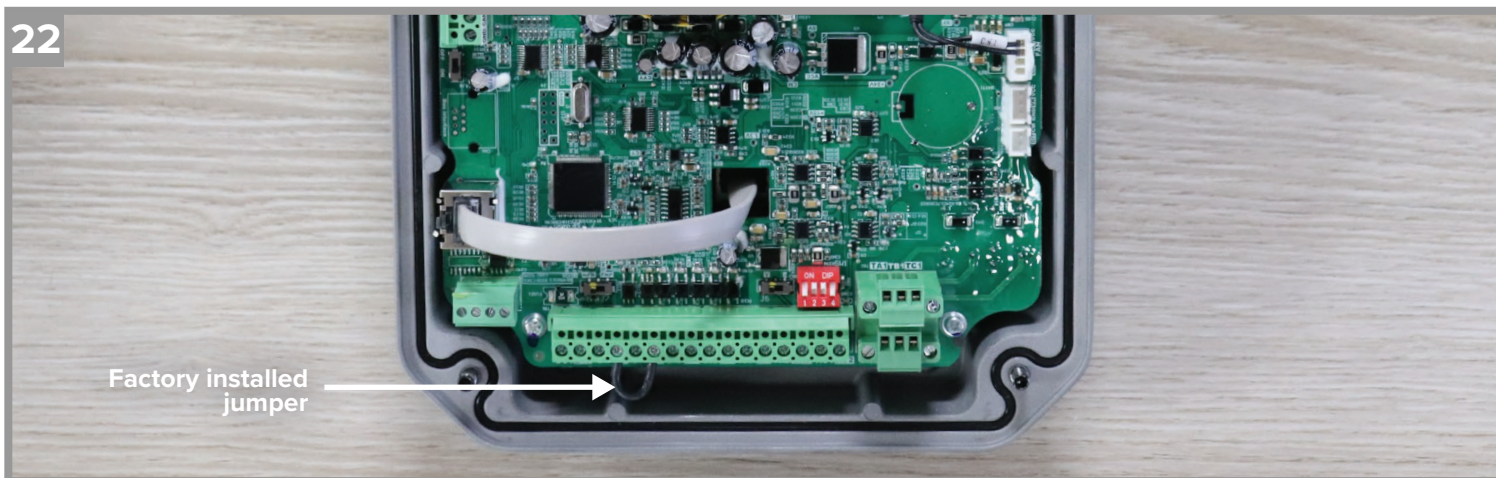

2

Connect the fire suppression system wires from the dry contacts on the relay to terminals COM and DI2. Route the fire system cable out via the provided strain relief.

3

Drive is now wired to shut down upon activation of any fire suppression signal. VFD expects a close contact in order to run.