

LH48

DIRECT DRIVE LIVE HAUL/AGRICULTURAL FAN

Ideal for poultry houses, dairy barns, and greenhouses, the LH48 live haul or agricultural fan has a robust galvanized steel construction for long-lasting corrosion resistance.

Making it ideal for commercial and industrial usage, it features a permanently sealed ball bearing and an IP55 motor rating. Each box fan includes mounting holes in the cabinet for hanging options.



Shown with optional wall box kit

FEATURES

- Galvanized steel construction for long lasting corrosion resistance
- Permanently sealed ball bearings
- IP55 motor rating
- Mounting holes on frame
- Tested per per ANSI / AMCA Standard 210-16, in a AMCA certified test facility

APPLICATIONS

- Poultry
- Dairy
- Greenhouse
- Commercial
- Industrial

SPECS

MODEL	BLADE DIAMETER	HP	DRIVE	CFM	RPM	VOLTS	AMPS	PHASE	HZ	SHAFT DIAMETER	DB @ 7'
LH48B-FS	48"	1	Direct	22,000	840	460	4.4-4.2/2.1	3	60	5/8	78.8

LH48B-FSB - Box Kit Included

DIMENSIONS

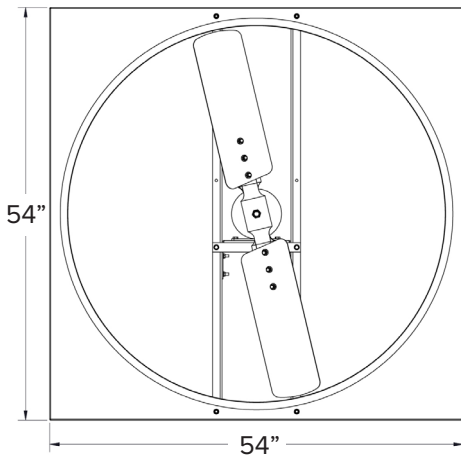

Front View

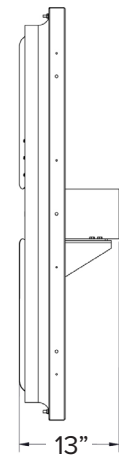

Side View

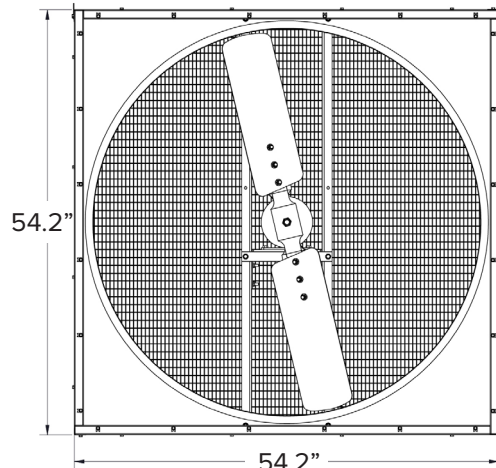

Front View
Front Guard not shown

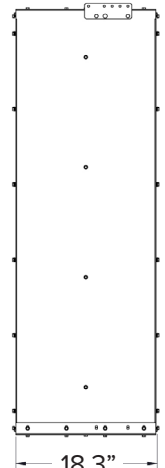

Side View

FAN SHROUD ONLY

WITH OPTIONAL WALL BOX KIT

- Screens are 1/2"x1"
- Wall Box is G-90 galvanized steel

